

Industrialisation of the Parts Decontamination Process

Franz Borrmann

PARTS DECONTAMINATION MARKET

Mass Balance Boiling Water Reactor

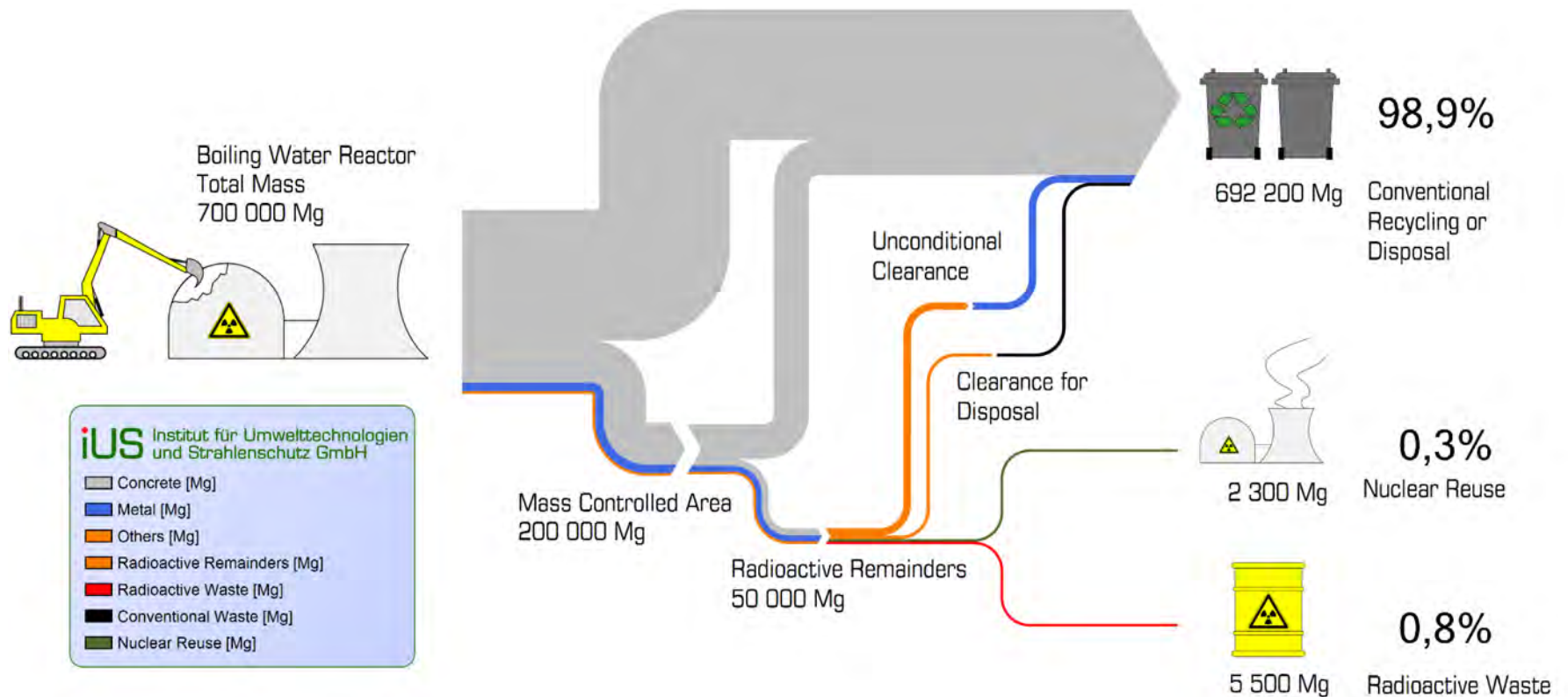

Cost of 1 m³ Radioactive Waste in Germany



Picture: Mercedes-Benz

Boundary Conditions (Germany)

- Radioactive Waste is Expensive
- Clearance is an Alternative Pathway and Extensively Used
- Driven by the Clearance Regulations, the Averaging Mass and Surface are Limited
- Clearance Limits tend not to Increase
- Documentation is Key

Boundary Conditions (Germany) II

- Overall Energy Market has Changed
- Revenue Generation from Operation of Large Powerplants became Difficult
- Unclear Situation with Regard to SF-Disposal
- Utilities have sued Federal and State Regulators for Fukushima-related Shutdowns

Mass of Metals from System Dismantling

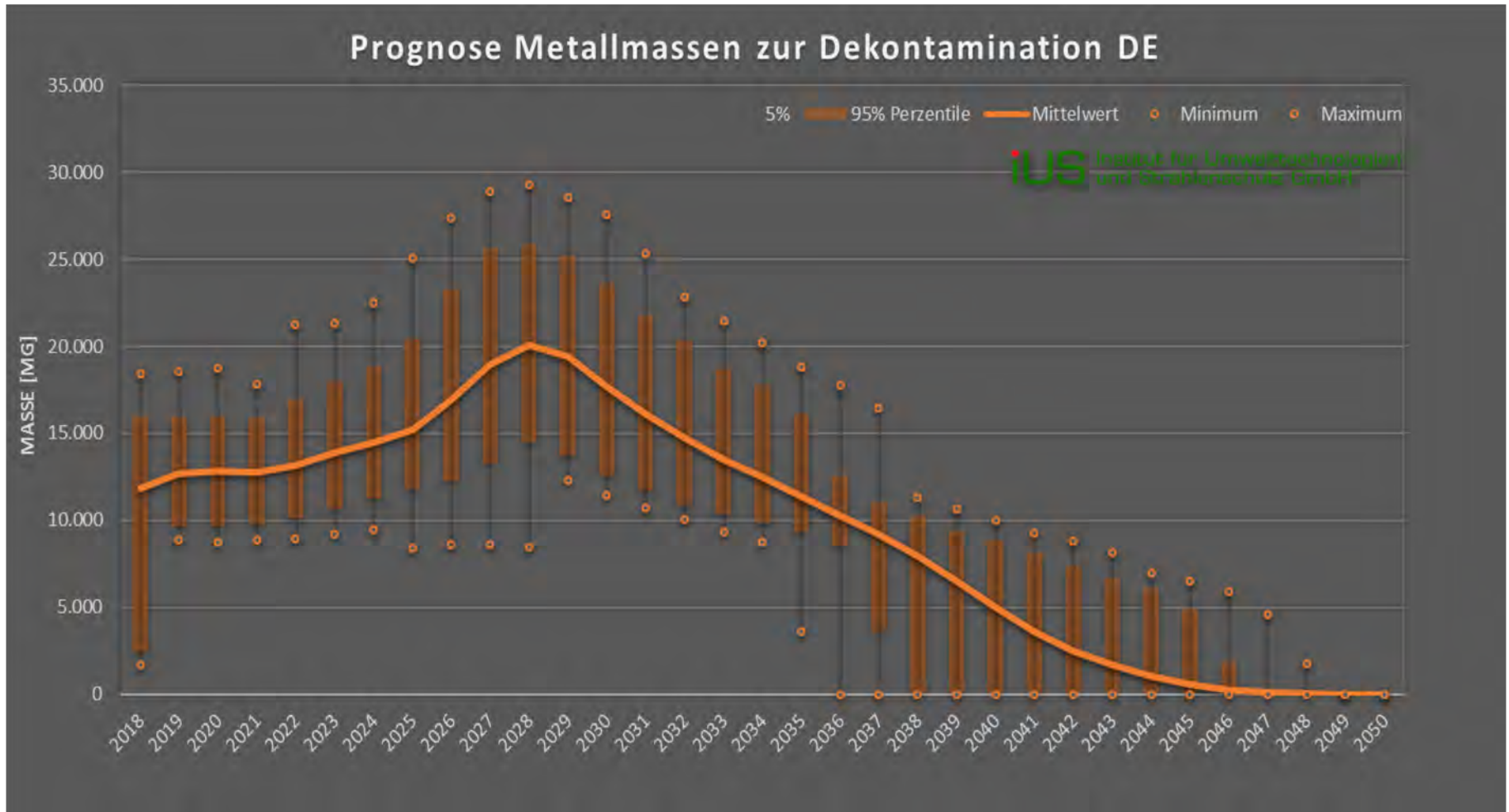

STATUS QUO

State of Automation

„The Standard Automation Device in Nuclear Decommissioning in Germany is the Whitebeer driven Lower Bavarian.“

Manual Decontamination

Physical Stress

Labor Efficiency

External Radiation

Cross-contamination



Incorporation Risk

Mechanical Hazard

Mental Stress

PPE

Logistics

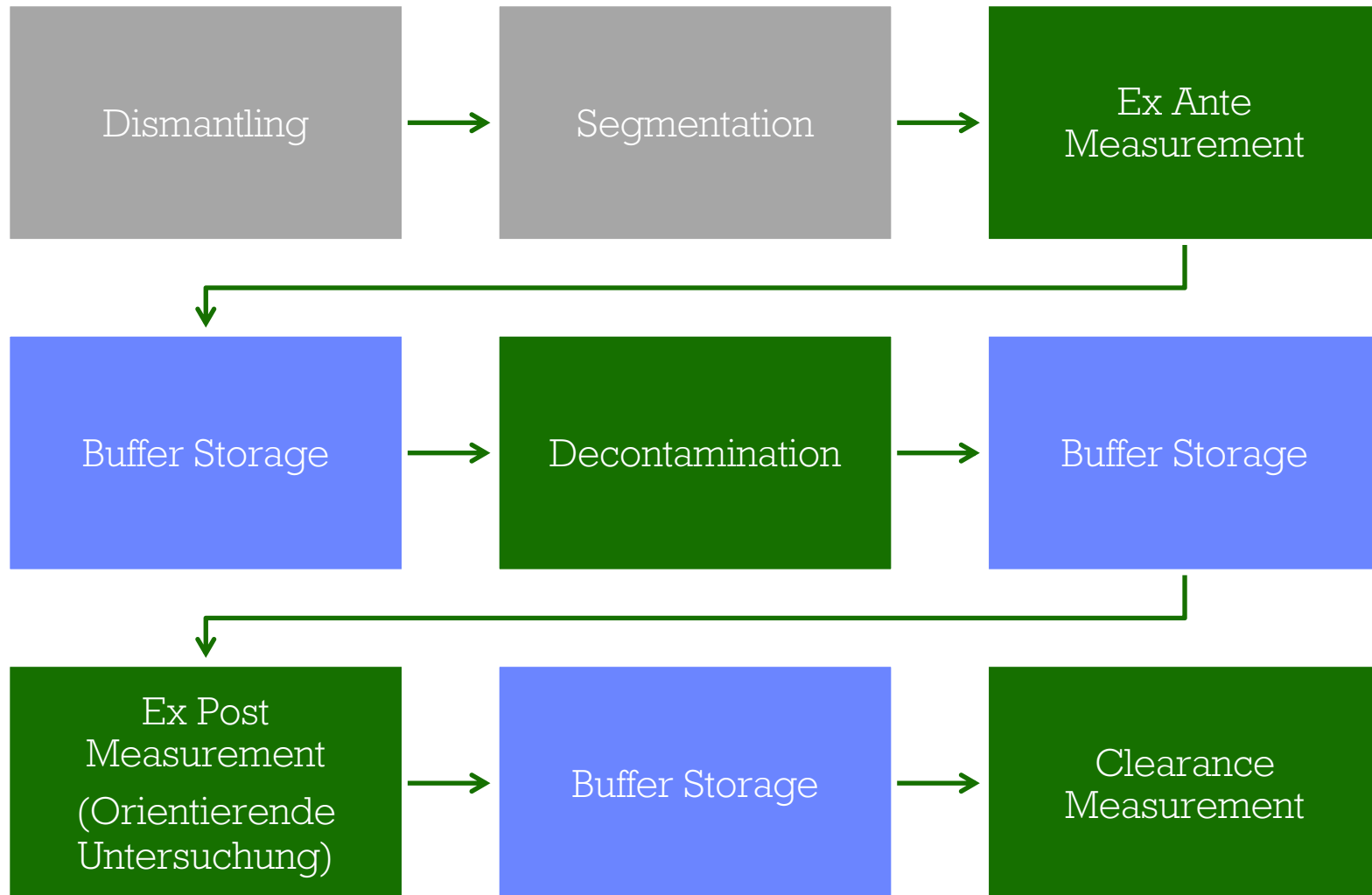

Summary of Status Quo Deficiencies

- Safety
- Limited Labor Efficiency
- Secondary Waste from PPE
- Cross Contamination Risk
- Buffer Storage Space
- Multiple Measurements with Different Devices
- Documentation
- Logistics

SOLUTION

Parts Decontamination and Clearance in a Common, Automated Process

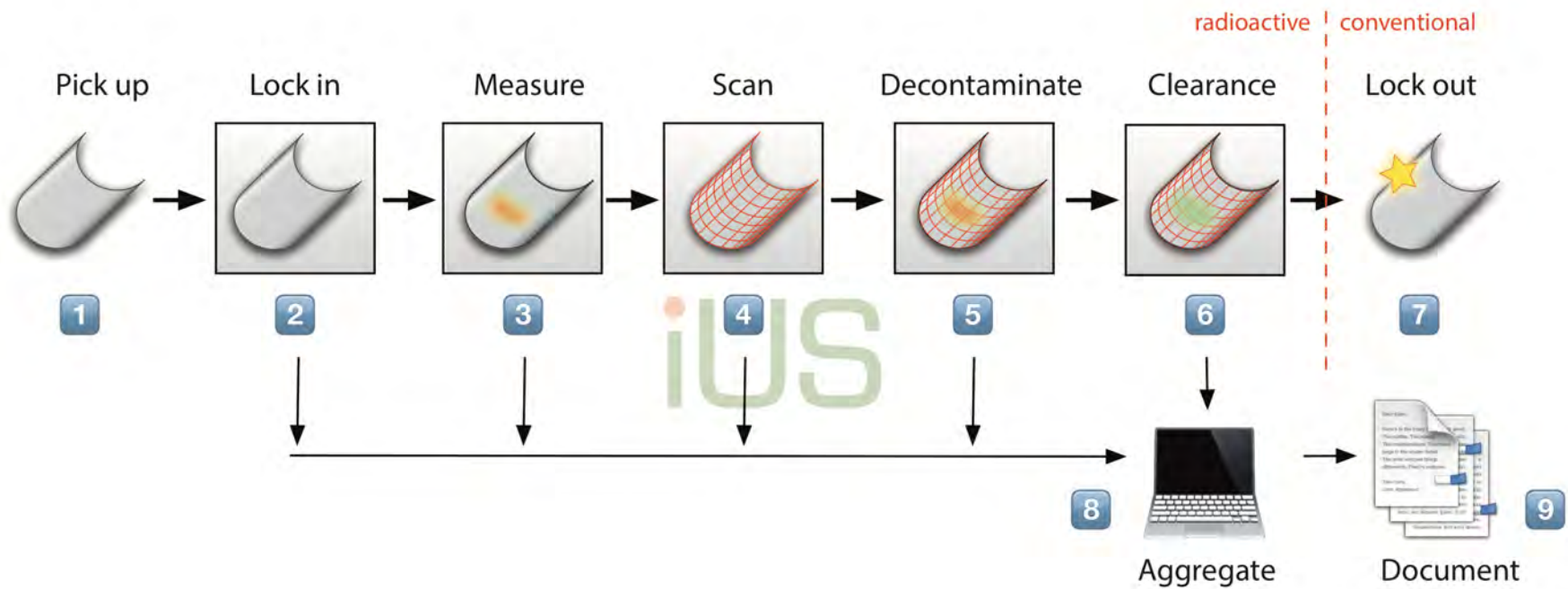

Example Configuration

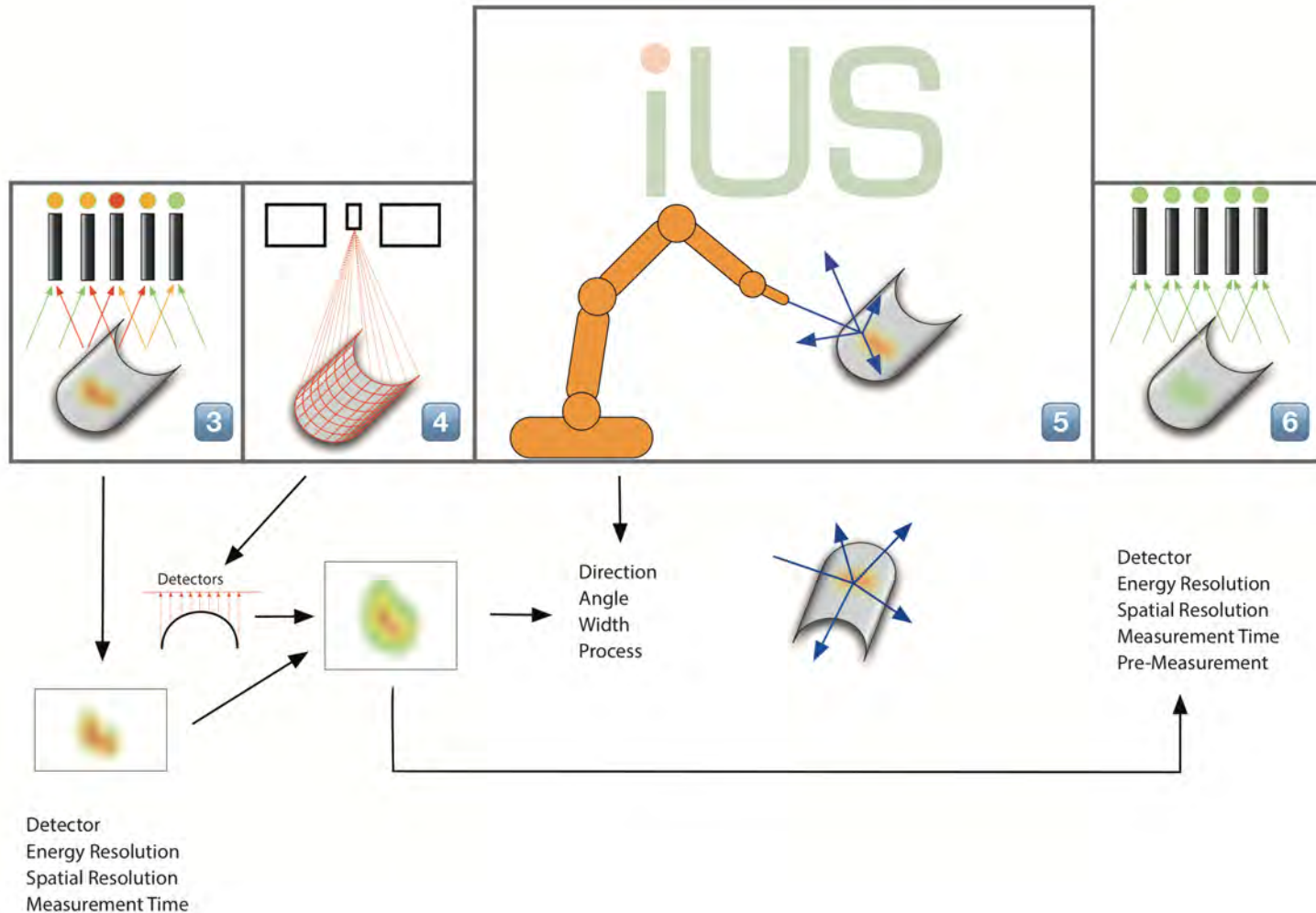

Ex Ante Measurements

- Detector Type
 - Energy Resolution
 - Detection Time
 - LoD
- Geometry, Number
 - Spacial Resolution
- Shielding
 - Detection Time
 - Background
 - LoD
- Nuclide-resolution or Energy-selective

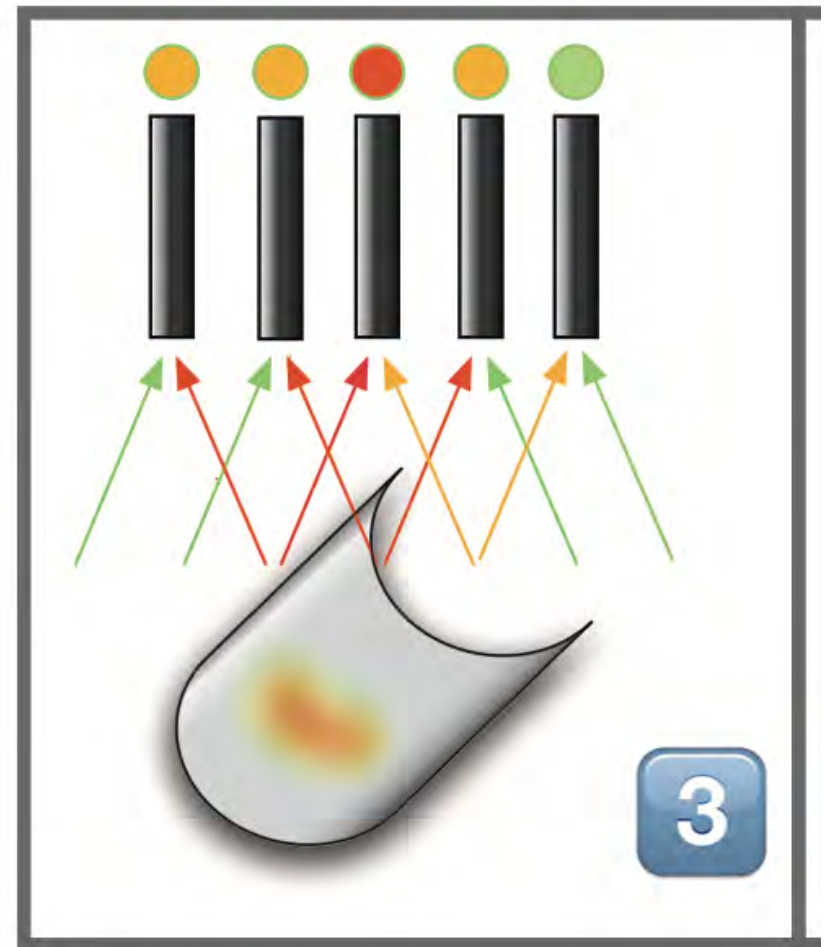

3-D-Imaging

- Industry Standard
- Several Methods available
 - Laserscan
 - Grid Projection
 - Photogrammetry
- Computer readable Structure Information

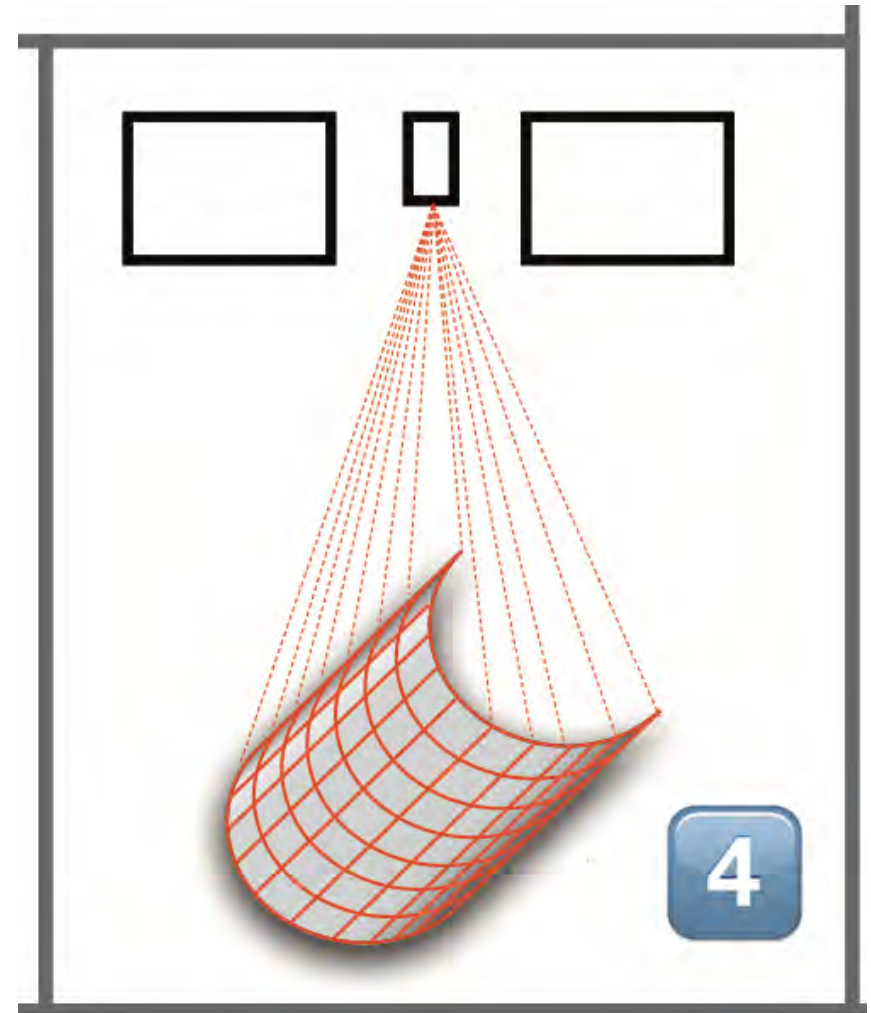

Decontamination

- Robot-guided decontamination tools, e.g. HPWJ
- Angle, Pressure and Orientation can be adapted to outcome of Measurement, Type of Contamination and Geometry
- Self-Learning system feasible, taking into account the ex-ante and ex-post measurements

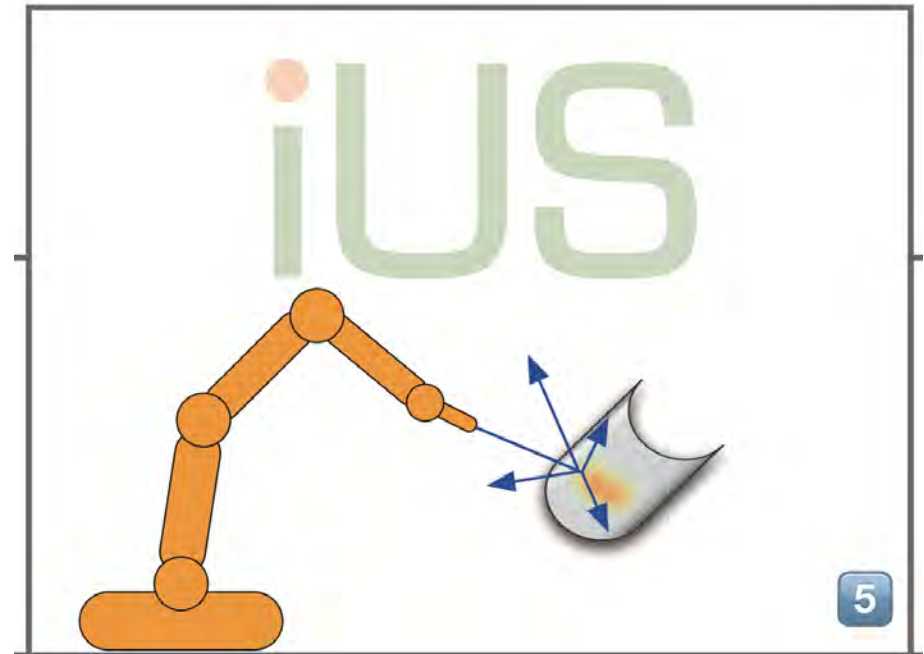

Clearance Measurement

- Taking into account known Measurement Results from Ex-Ante-Measurements
- Adapted to requirements, Different Configurations possible, also in parallel (to allow longer measurement times)
- Marking of every Piece (e.g. QR Code)

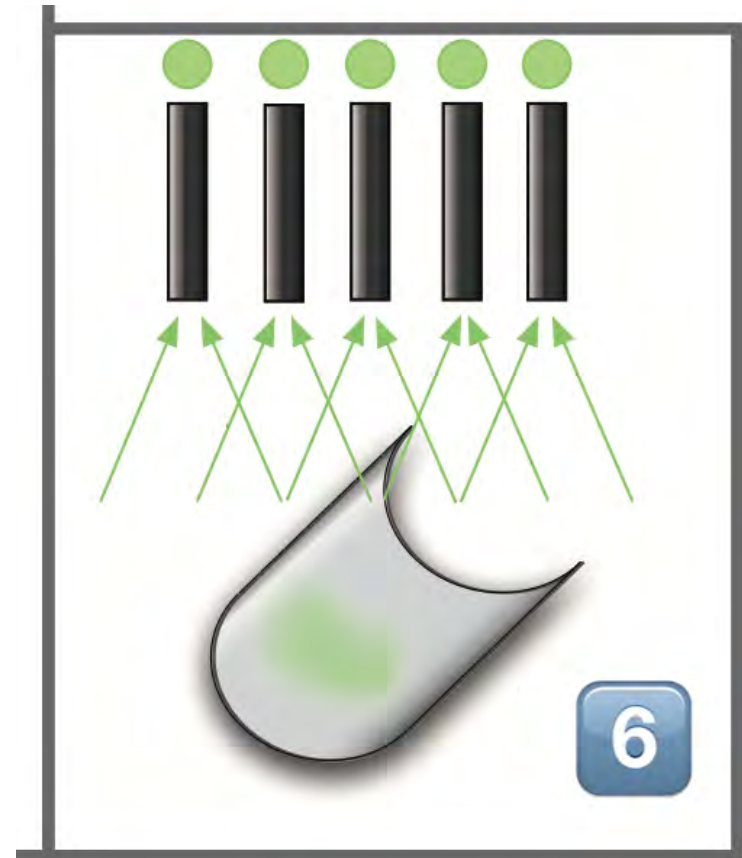

Documentation

- Documentation for
 - Configuration Management
 - Maintenance
 - Measurement Equipment
 - Identification
 - Physical properties
 - Clearance
 - conventional Waste

Automated Documentation

- Summary of scanning data
- Summary of geometry recognition
- Aggregation of treatment data
- Aggregation of measurement data

- Raw data for analytical purposes

Semantic Documentation

- All machinery delivers to the same format
- Semantic format is human AND machine readable
- All Steps, all outcomes can be aggregated on one single web page for a piece of residue, links to calibration etc.
- TSO and authority can easily check every step by reading the QR code with a standard smartphone or tablet
- Real time reporting, with full transparency at reduced cost
- Easy Configuration Management and Maintenance information in Real time

ADVANTAGES

Advantages

- Minimalisation of Human Intervention
- 24/7 Operation possible, high Labor Efficiency
- Less Buffer needed, from Pick-up to Clearance in one go (Depending on Configuration)
- Modular Approach, Adaptation to the Needs of specific Projects or Phases
- Fully Transparent Documentation Approach Built in, Traceability of each Part
- Easy Configuration Management, Industry 4.0

DEVELOPMENT

Current Lab - Robot System



Computer Vision

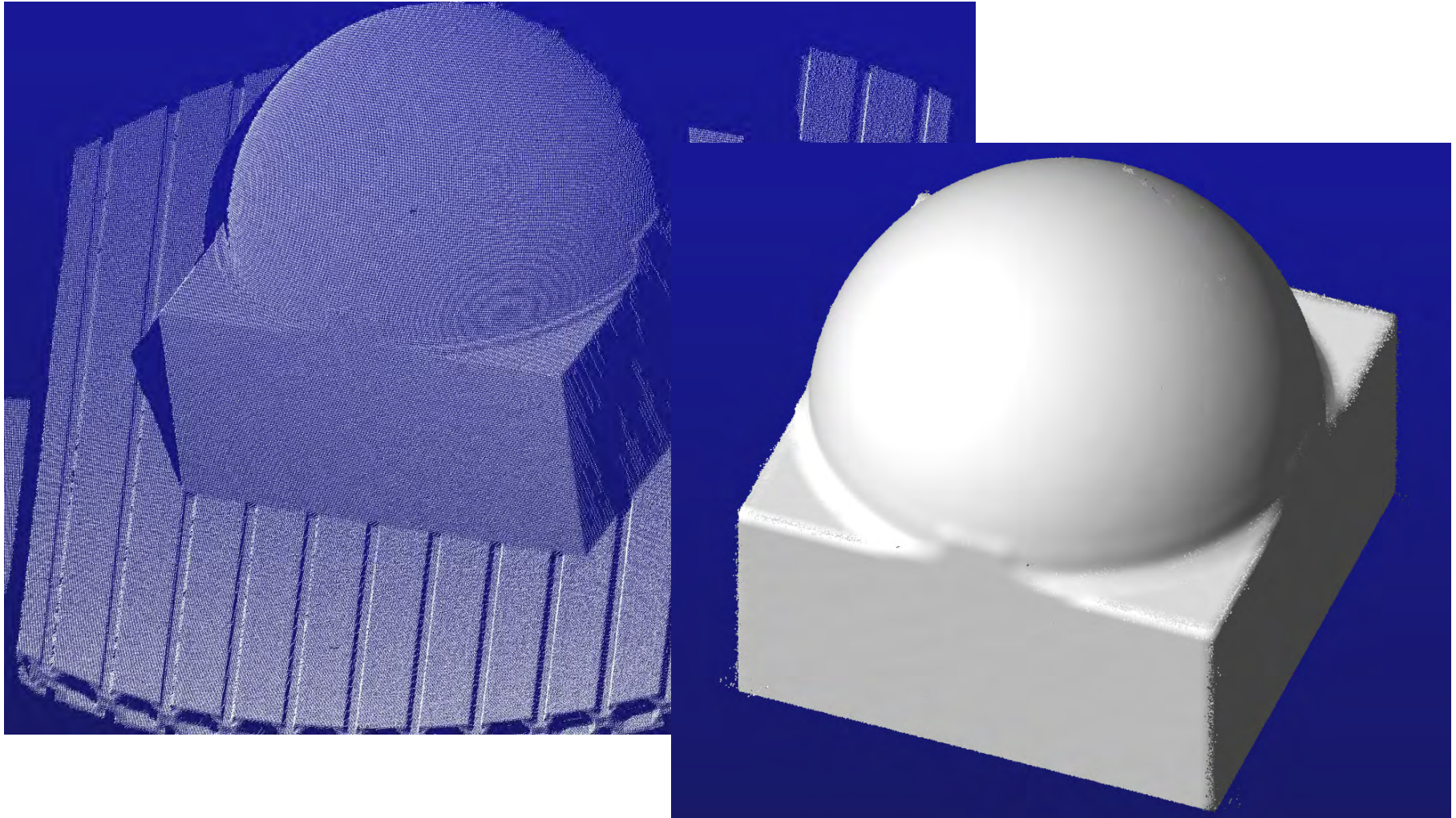

Pathway calculation

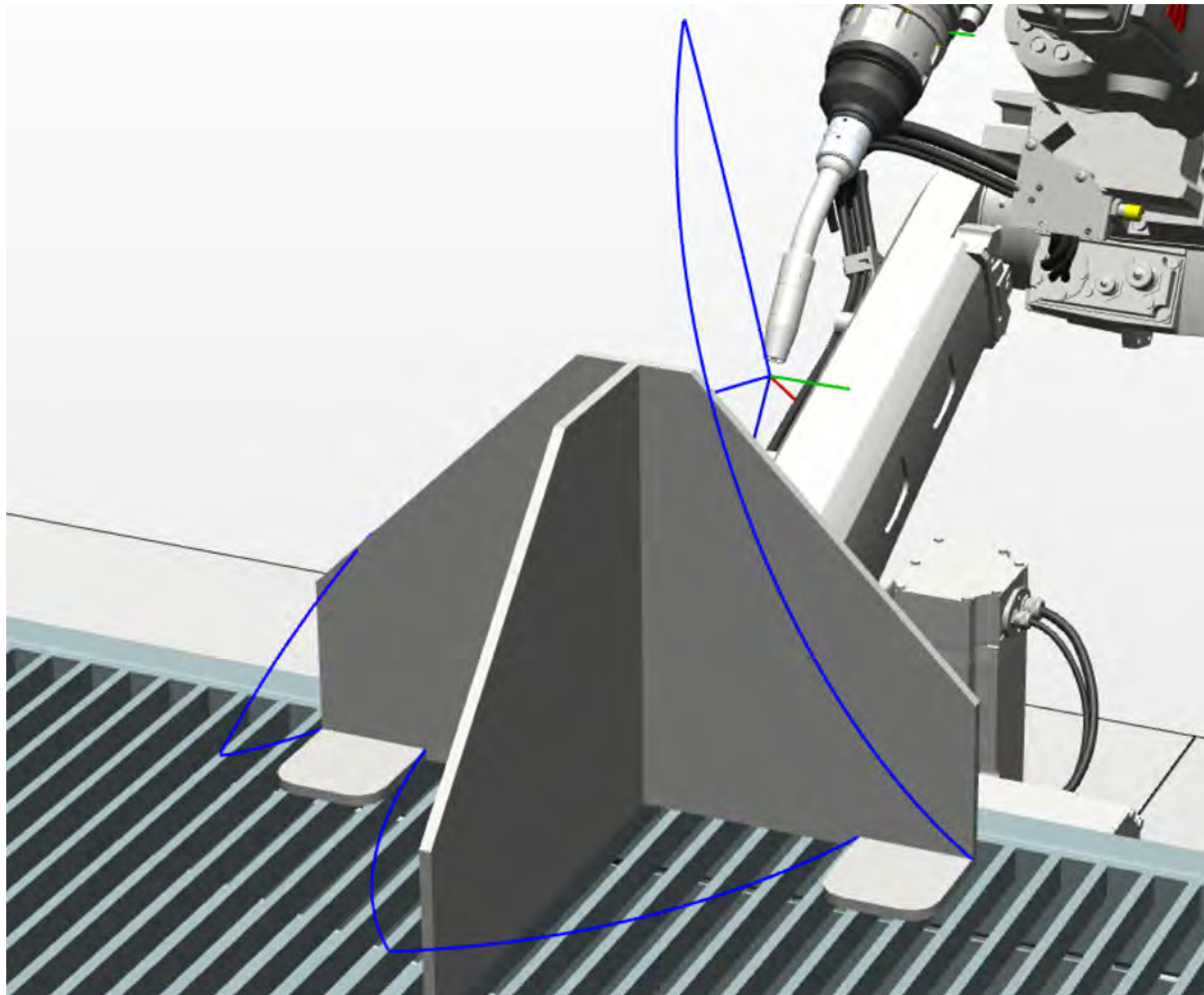

Licensing aspects

- Security concept development
 - Several programming levels
 - Each level separated from others
 - Takes into account disruptive acts from insiders

- Safety concept development
 - Integrity of containment
 - Ensuring underpressure in cabin
 - Emergency stop conditions

Documentation based on industry 4.0

- Development of prototype ongoing
- Industrial Pi-based processing
 - Reading bus systems
 - Analogue and digital sampling
- Aggregated values are then written into a semantic system

Current Prototype Data System

